



November

Mobileye 8 NC (800/880)

Technical Installation Guide v0.4



Table Of Contents

Table Of Contents	1
1. Warnings	4
1.1 General	4
1.2 Installation & Safety Instructions	5
2. Components Overview	6
3. Software download & installation	8
4. Connection Scheme	9
4.1 CAN-bus Installation Scheme	9
4.2 Mixed Installation Scheme (Analog + CAN-bus)	9
Analog Installation Scheme	10
5. Connection Description	11
5.1 Introduction	11
5.2 Main unit connections (CAB000400 Rev3.3)	11
5.3 Mobileye 8 signals cable (CAB000371 Rev6.3)	11
5.4 Ferrite	13
5.4.3 Ferrite for Power Sources -Model 2 (ITM000786)	13
5.4.4 Instructions for power sources (CAB000371)	13
5.5 EyeWatch 3 – display and control unit (CAB000087) -OPTION 1	14
5.6 EyeWatch 8 – display and control unit (CAB000401) -OPTION 2	14
5.7 CAN Reader – CAB000302	15
5.8 EyeNET – (EYENET0001 / CAB000613)	15
6. Connection Description	16
6.1 Site preparation	16
6.2 Vehicle signals connections	16
6.3 EyeWatch Installation	17
6.4 Mobileye 8 main unit (camera) installation	18
7. Installation & Calibration procedure	20
7.1 Back-Cover removal	20
7.2 Communication / Connection phase	21

7.3 System Calibration	22
7.3.1 Login	22
7.3.2 Login	23
7.3.3 Vehicle Selection	25
7.3.4 Connection to SeeQ	26
7.3.5 Vehicle Information	27
7.3.6 Vehicle Information	28
7.3.7 Analog Installation	29
7.3.8 Signal Test	30
7.3.8.1 Signal Test Troubleshooting	31
7.3.9 Calibration	32
7.3.9.1 Step 1 – TAC assembly	32
7.3.9.2 Step 2 – Camera attachment	33
7.3.9.3 Step 3 – Measurements	35
7.3.9.4 Step 4 – Camera angle adjustment	38
7.3.9.5 Step 5 – Car hood	38
7.3.9.6 Step 6 – Calibration	39
8. Appendix A – CAN Reader	42
9.1 General	42
9.2 CAN Reader installation (CAB000302)	43
9.3 Technical Specifications	44
Mobileye® 8 Technical Specification Sheet	44
Mobileye® 8 Display unit Specification Sheet	45
Mobileye® 8 Certificates	45
9. Appendix B – up/down configuration	46
9.1 General	46
10. Appendix C – EyeNET Holder (ASY000451)	49
10.1 Introduction	49
10.2 Component Overview	49
10.3 Assembly	49
11. Appendix D – Calibration Tool	51
2 Mobileye 8 NC (800/880)	



11.1	Introduction	51
11.2	Instructions	51
12.	Troubleshooting	53

1. Warnings

1.1 General

Mobileye 8 is Mobileye's new driver assistance system, containing the latest iteration in Mobileye's state-of-the-art machine vision software – the EyeQ®4 system-on-chip.

Mobileye 8 alerts the driver, aurally and visually, to certain potentially dangerous situations on the road; the greater the danger, the more 'urgent' the warning.

Mobileye 8 is not an automated driving system. It does not replace the driver nor allow the driver to be any less vigilant or alert to the road than he/she would otherwise be. It does not reduce the driver's responsibility for driving properly, nor his/her liability for driving improperly or unlawfully. In particular, the driver should ensure not to be distracted from the road by the Mobileye 8 display unit.







Mobileye 8 works best on paved roads with clear lane markings. Even then, Mobileye cannot guarantee 100% accuracy nor the absence of false positives ('seeing' something that's not there) or false negatives (failing to 'see' something that is there), especially in adverse road or weather conditions.

Mobileye 8 is designed to detect only fully visible vehicles and fully visible pedestrians and bicycles (both in daylight and at night). It is not designed to detect crossing, oncoming, or passing vehicles.

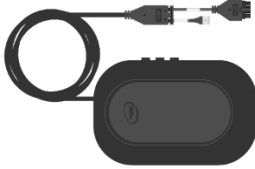
1.2 Installation & Safety Instructions

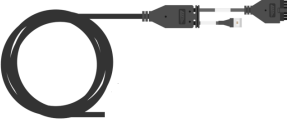
- ✓ Mobileye 8 installation must be carried out by an authorized Mobileye 8 dealer or Installer.
- ✓ Do not transfer Mobileye 8 to another vehicle after installation.
- ✓ Operate Mobileye 8 only with 12VDC~24VDC power.
- ✓ Do not cover or obstruct the Camera Unit or Display and Control Unit.
- ✓ Use proper tools.
- ✓ Use only an LED voltage tester or digital multi meter. Do not use a light bulb voltage tester.
- ✓ Pay attention to unusual color cables, for example: yellow cables belong to air bags; two twisted wires usually belong to different (digital) sensors.
- ✓ Before disconnecting the battery or radio connectors make sure to have the radio code in hand.
- ✓ Do not disconnect any plug or connector in the vehicle while the car's ignition switch is on.
- ✓ Before making the power connections, extract the Fuse from the Fuse holder and add it back only after all system components and cables are connected and before turning the vehicle power On.
- ✓ **Use protective gloves when handling the camera unit to protect against heat burns.**

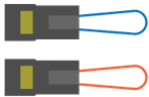
2. Components Overview

Package List	Component	Mobileye P/N
Camera unit		ME8000000000VSSNC \ ME8000000000VSSNC \ ME8000000000ETH4G
Display unit – EyeWatch	EyeWatch 3  EyeWatch 8 (Optional) 	ASY000130 (EW3 Supplied only with ME8000000000VSSNC) PAC0000000000EW8
Main cable		CAB000400 Rev3.3
Signals cable		CAB000371 Rev6.3
CAN Reader		CAB000302 Rev.0.3
External fuse holders with 2A fuses		Fuse - ITM000205 Fuse holder (Red) - ITM000206 Fuse holder (Blue) - ITM000207
3M VHB Surface Cleaner		ITM000024

Ferrite		ITM000786 – Ring Ferrite
---------	---	--------------------------

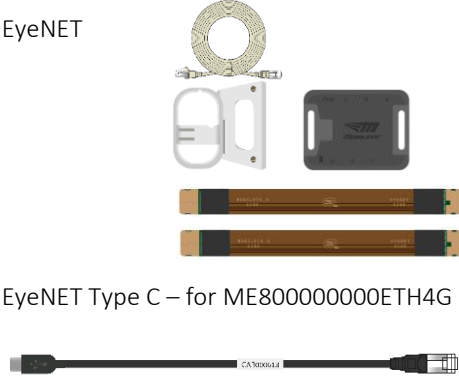
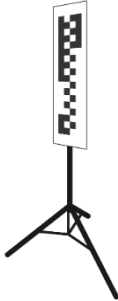
Installer Kit			
EyeNET	<p data-bbox="496 533 576 562">EyeNET</p>  <p data-bbox="496 797 951 826">EyeNET Type C – for ME800000000ETH4G</p>	used for system installation, calibration, and configuration	<p data-bbox="1238 544 1406 573">EyeNET0001</p> <p data-bbox="1230 815 1382 844">CAB000613</p>
TAC		used for both the main camera attachment to the windshield (reference point) and for calibration calculation	TACS00003

 Note

The Mobileye EyeNET is not part of the Mobileye 8 kit and is sold separately.

3. Software download & installation

Mobileye 8 series uses a dedicated applications for configuration and calibration*.

The applications are part of the **Mobileye Installation Center**.

The software installer is available in our website under "support" tab or in the following direct link:

<https://www.mobileye.com/support/>

Note

Please make sure you have Administrator Privileges before installing the Mobileye IC application, if not, please contact your IT department for further assistance.

Note

To keep the most up to date version of the IC application, login with your login details to enable to automatic update. If an update is available, follow the on-screen

4. Connection Scheme

4.1 CAN-bus Installation Scheme

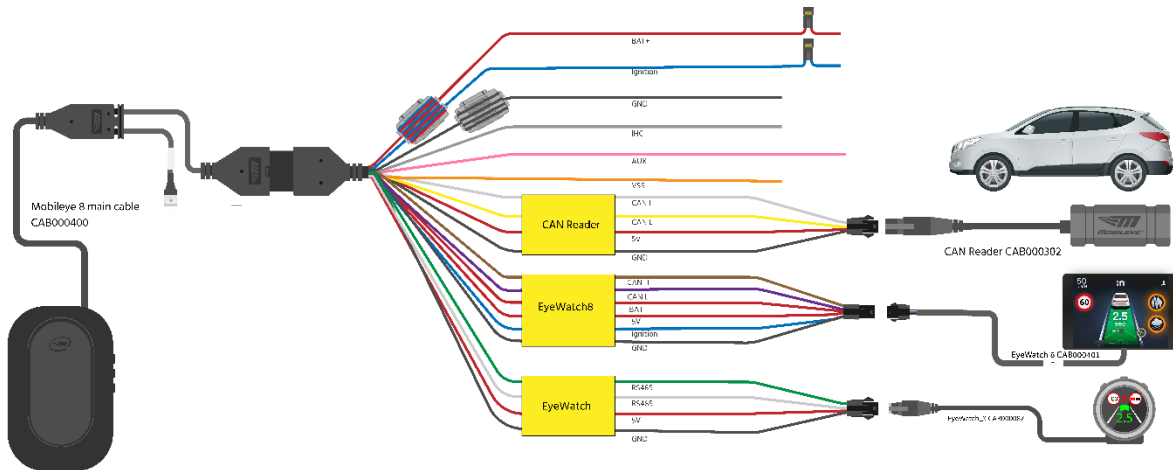

4.2 Mixed Installation Scheme (Analog + CAN-bus)

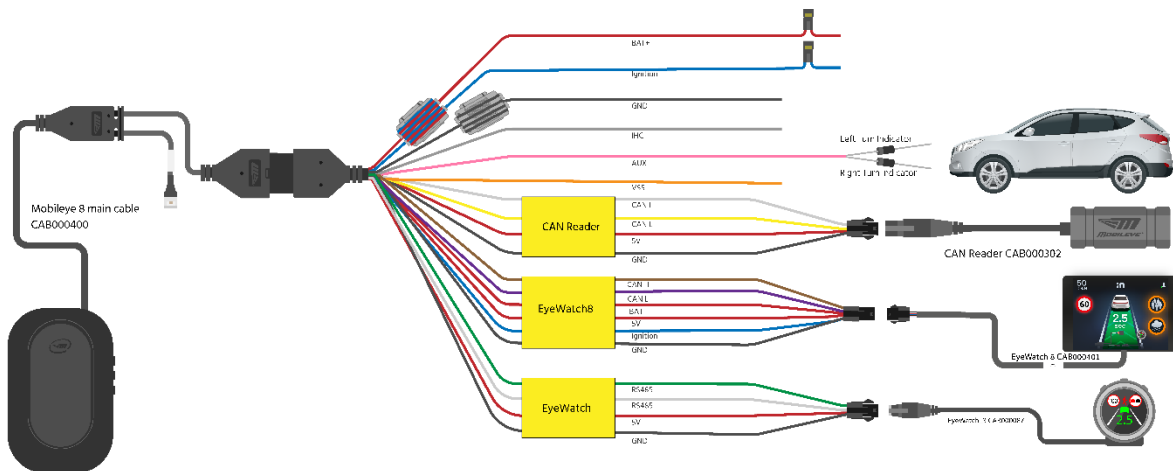

Analog Installation Scheme

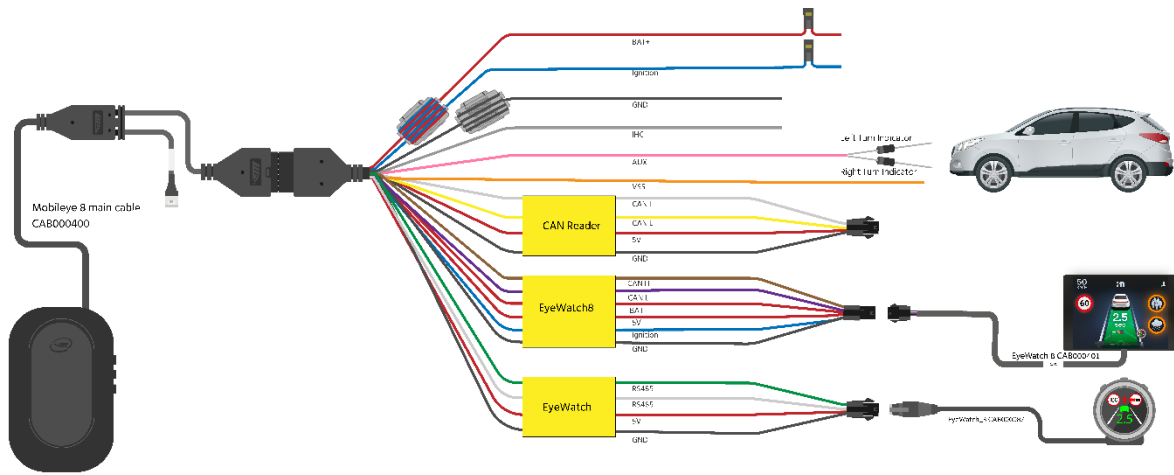

5. Connection Description

5.1 Introduction

The following paragraphs describe in detail the function and connections of the system's components.

5.2 Main unit connections (CAB000400 Rev3.3)

Wire Name & Function	Wire color	Connector	Connection To
Signals - (14 pin connector)	Black	J1	Vehicle signals cable (CAB000371 rev.6.3)
GPS - (5 pins White connector)	Black	P2	NOT IN USE

Table 1: Mobileye 8 Connect cable connections.

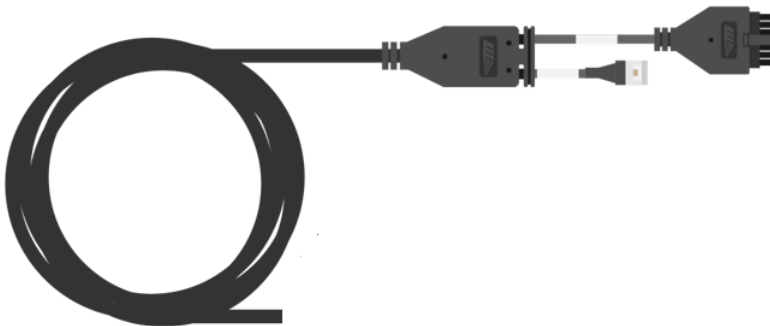

5.3 Mobileye 8 signals cable (CAB000371 Rev6.3)

The Mobileye 8 signals cable splits into a few cables which connect to the vehicle power source, to the vehicle CAN-bus (Via CAN Reader connector), to the vehicle analog speed signal, to the vehicle high-beams (for IHC), to one of the vehicle's analog signals if required (or both analog left- and right-turn indicator signals via diode), to the EyeWatch display unit (via 4 pin male connector labeled as "EyeWatch" and it contains a 6-pin female connector labeled "EyeWatch 8" to provide future connection for new EyeWatch unit.

A detailed description of each of the wires in the analog cable can be found in the following table below:

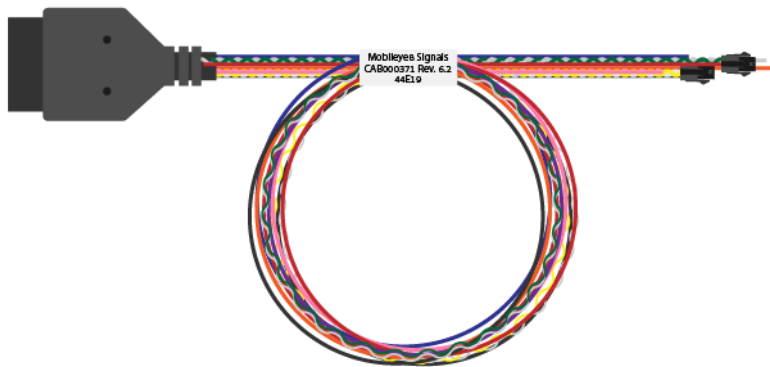

Wire Name & Function	Wire color	Connector	Connection To
BAT+ (12/24V)	Red	-	Vehicle`s constant power (Battery)
GND	Black	-	Vehicle`s GND (BAT-)
Ignition (12/24V)	Blue	-	Vehicle`s ignition signal
CANBH	White	4pin	CAN Reader
CANBL	Yellow	4pin	CAN Reader
5V for CAN Reader	Red	4pin	CAN Reader
GND for CAN Reader	Black	4pin	CAN Reader
VSS	Orange	-	Vehicle`s Analog speed signal
CAN A High	Purple	6pin	EyeWatch 8
CAN A Low	Brown	6pin	EyeWatch 8
5V for EyeWatch 8	Red	6pin	EyeWatch 8
GND for EyeWatch 8	Black	6pin	EyeWatch 8
AUX (Analog Input)	Pink	-	1 analog signal input (or both Left and Right Turn indicators analog input via Diode)
IHC – (Analog Output)	Gray	-	Vehicle`s high beams via external relay or connection to any 3 rd party device
RS-485 High	Green	4pin	EyeWatch 3
RS-485 Low	White	4pin	EyeWatch 3
RS-485 GND	Black	4pin	EyeWatch 3
RS-485 5V DC	Red	4pin	EyeWatch 3

Table 2: Mobileye 8 Connect analog signals cable connection

5.4 Ferrite

5.4.3 Ferrite for Power Sources -Model 2 (ITM000786)

Note

The Ferrite size and shape may vary different between different Ferrite models.

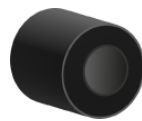

5.4.4 Instructions for power sources (CAB000371)

Please follow the instructions bellow for the two ferrites installation:

1. Open the Ferrite using a small flat screwdriver.
2. Place both Mobileye **BAT+** wire and **Ignition** wire (CAB000371) together inside the **first Ferrite**.
3. Locate the Ferrite 5cm from the Mobileye CAB000371 label
4. Wrap the **BAT+** and **Ignition** wires **through** the Ferrite **2 times** **and around** the outside of the Ferrite **1 times**, as shown in the figures
5. Lock the Ferrite

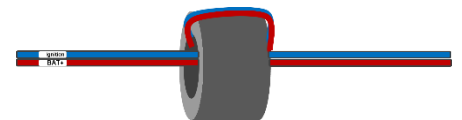

6. Open the second Ferrite using the supplied Key or small flat screwdriver.
7. Place the Mobileye **GND** wire in the second Ferrite (locate the Ferrite filters 5cm from the Mobileye CAB000371 label).
8. Wrap the GND wire **through** the Ferrite **2 times** **and around** the outside of the Ferrite **1 times**, as shown in the figures.
9. Close the Ferrite

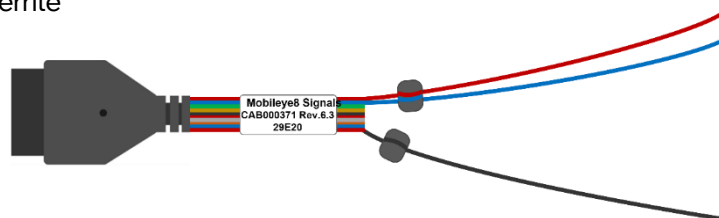

Note

- ✓ Ferrite installation on power lines is mandatory in CE marking countries.
- ✓ Ferrite installations are not mandatory for FCC and E-Mark certificates.

5.5 EyeWatch 3 – display and control unit (CAB000087) -OPTION 1

The EyeWatch 3 is connected to the Mobileye 8 EyeWatch female connector (J1) using the EyeWatch connecting cable male connector (J1).

Table 3: EyeWatch connections

Wire name	Wire color	Connector	Connection to
EyeWatch Cable (CAB000087)	Black	J1 - Female	EyeWatch 4pin male connector in CAB000371
EyeWatch (CAB000371)	Black	J1 – Male	ME8 Signals cable 4 Pin connector for EyeWatch unit

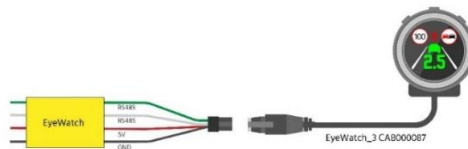

5.6 EyeWatch 8 – display and control unit (CAB000401) -OPTION 2

The EyeWatch 8 is connected to the Mobileye 8 signals cable with the EyeWatch male connector (P1) to the Signals cable EyeWatch 8 female connector (P2).

Table 3: EyeWatch connections

Wire name	Wire color	Connector	Connection to
EyeWatch 8 Cable (CAB000401)	Black	P1 - Male	EyeWatch 6 pin female connector in CAB000371
EyeWatch (CAB000371)	Black	P2 – Female	ME8 Signals cable 6 Pin male connector for EyeWatch 8 unit

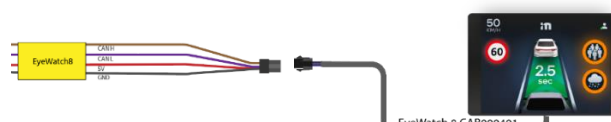

Note

EyeWatch 8 is compatible only with ME8 units with the following cables:

- ✓ Display unit will be supplied only with the ME8000000000VSSNC
- ✓ CAB000371 Rev6.3 and up.
- ✓ CAB000400 Rev3.3 and up.

5.7 CAN Reader – CAB000302

The Mobileye CAN-Reader is a non-intrusive solution for CAN-bus connection.

The Mobileye CAN Reader will allow you to better handle a CAN-bus reading by simply placing the sensor on the vehicle CAN-bus wires without any wire cutting or pinching.

Wire name	Wire color	Connector	Connection to
Power sources and signals cable (CAB000371)	Red, Black, Yellow and White	Male	Mobileye CAN Reader
Mobileye CAN Reader (CAB0003002)	Black	Female	Power sources and signals cable (CAB000371)

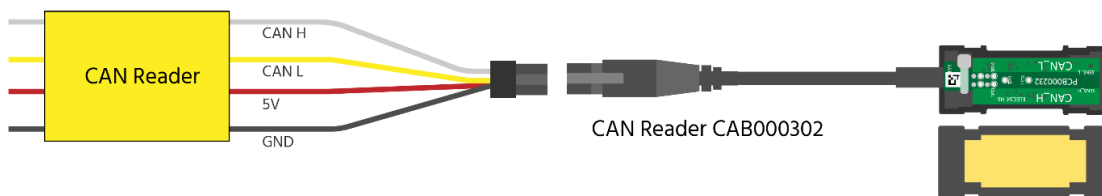

5.8 EyeNET – (EYENET0001 / CAB000613)

The Mobileye 8 service port female connector (P2) is used to connect to the Mobileye EyeNET short cable male connector labeled “MOBILEYE8 SIDE” (J5).

Wire name	Wire color	Connector	Connection to
EyeNET short cable (BRD000350)	Brown	Male	Mobileye 8 service port
EyeNET Ethernet LAN port		Female	LAN port for Ethernet cable between the EyeNET and the PC
Mobileye 8 service port		Female	EyeNET cable

Table 4: EyeNET connections

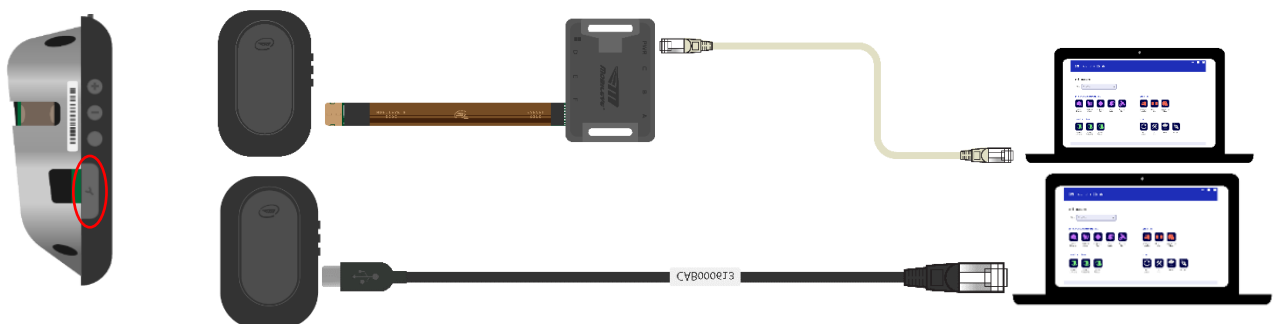

6. Connection Description

6.1 Site preparation

- ✓ Make sure the vehicle is parked on a flat surface (no slope).



- ✓ Check vehicle speed signal availability (either by CAN-bus or by Analog) to determine which type of installation will be for the Master camera (CAN, Analog, Mix).

6.2 Vehicle signals connections

Warning

Identifying the vehicle's electrical signals requires having the keys in the ignition in the ACC (Accessory) position or ignition ON. Make sure the car headlights and/or any other power consuming devices/applications, e.g., air conditioning, are turned off during Mobileye 8 Connect installation to prevent battery drainage.

Please ensure to identify the Mobileye 8 cables according to table below.

Identified vehicle's signals	Wires label	Wires color
Vehicle battery (Constant 12V~24V) via 2A fuse	BAT+	Red
Ignition (12V~24V) via 2A fuse	Ignition	Blue
Vehicle GND	GND	Black
CAN B High	CAN Reader	White
CAN B Low	CAN Reader	Yellow

6.3 EyeWatch Installation

Caution

- ❖ The EyeWatch unit should be placed in a location that does not obstruct the driver's field of vision
- ❖ The EyeWatch should not be placed in front of the air-bags operational space as it may otherwise prevent the airbag from fully opening or cause injury during air-bag activation

Select the optimal location for the EyeWatch attachment:

1. The EyeWatch should be placed on the dashboard or windshield at a location within the driver's field of view, conveniently visible while driving, and allowing access to its controls while sitting comfortably in the driver's seat (the EyeWatch mounting angle is adjustable by the installer — a Philips's screwdriver is required)
2. Clean the selected location with the provided 3M VHB Surface cleaner.
3. Attach the EyeWatch at the selected place (after removing the protective cover from the adhesive tape)
4. Remove the transparent protecting covering from the display surface.
5. Insert the EyeWatch cable (CAB000087/CAB000401) behind the vehicle trimmings so that it reaches the EyeWatch connector of the Mobileye 8 Connect cable (CAB000400)



6.4 Mobileye 8 main unit (camera) installation

Warning

Selecting the optimal location for the main unit is critical and can affect system performance. Please ensure to comply with the following guidelines.

- ❖ Minimum height for camera location is 1.2 meters (3.9 feet).
Maximum height for camera location is 2.65 meter (8.69 feet).

Note

In extreme cases and upon approval of Mobileye support team, it is possible to install the camera above 1.8 meters BUT this will void any REM data which can affect the project target.

- ❖ The unit must be in an area of the windshield which the windshield wipers reach.
- ❖ The unit should preferably be located at the center of the windshield.
Installing the unit off-center in a convex windshield will result an improper field of view, which will affect system performance. The camera's lens should always face straight ahead.
- ❖ Off-center installation is allowed up to 8%
EXAMPLE: if the vehicle width is 200cm (2M), camera can be attached up to 16 cm from the windshield center ($200 \times 0.08 = 16$). **Vehicle width in cm X 0.08 = MAX OFFSET**
- ❖ Camera roll-up is allowed up to 2°; if the camera roll is higher than 2°, the calibration will fail.
- ❖ There should be no obstruction, such as stickers or darkened windshield areas, in front of the main unit.
- ❖ In tall commercial vehicles that do not have an engine hood blocking the camera's field of view, the main unit can be placed on the lower part of the windshield; however, all the above-mentioned requirements must nonetheless be considered. In this case, you can modify the main unit cable to the "DOWN" position. "DOWN" means that after the main unit installation, the main cable exits from downwards instead of upwards (by default the cable exits upward from the "UP" position).

 Caution

- ❖ Attaching the camera unit to the windshield should take place only after receiving a live streaming video during calibration process.

The following paragraphs present the function of each cable and guide you through the actual connection procedures with the vehicle's signals.

1. Identify the wires in the vehicle that carry the required electrical signals (according to the table above).
2. After identifying the required signal's locations in the vehicle, pass the Mobileye 8 Connect cable (CAB000400) behind the vehicle trimmings so that it reaches all vehicle signals (it is recommended that you hang the Mobileye 8 Connect main unit on the rear-view mirror or place it on the dashboard before passing the cable behind the vehicle trimmings).
3. Firmly connect the appropriate wire from the Mobileye 8 signals cable (CAB000371) to the identified vehicle signal.
4. Each wire in the Mobileye 8 signals cable (CAB000371) mentioned above has a unique color. Make sure to connect the correct vehicle signal to its appropriate wire according to the table in page 12.
5. Keep the Mobileye 8 EyeCAN connector & EyeWatch connectors easily accessible.

 Warning

- Connect each power source led to its appropriate connection in the vehicle.
- Make sure the 2A fuses are kept easily accessible.
- Wires colors are not guaranteed. Always double-check wires' labels
- Always check the Mobileye vehicle database for CAN-bus availability before installation is started.

7. Installation & Calibration procedure

Warning

Before making the power connections, extract the Fuse from the Fuse holder and add it back only after all system components and cables are connected and before turning the vehicle.

7.1 Back-Cover removal

As part of the Mobileye 8 calibration process, the camera angle must be adjusted as outlined below.

To access the camera angle adjustment`s screw you must remove the main unit`s back cover.

To remove the back cover:

1. Using a small flat screwdriver, slide and push out the oval cover



2. Using a small Philips screwdriver, unscrew the 3 screws and remove the main back cover

3.

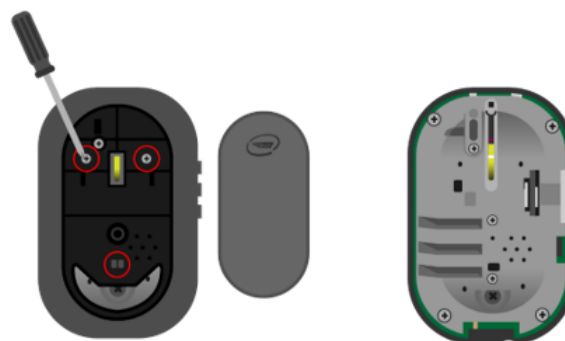

7.2 Communication / Connection phase

Mobileye 8 service port interface is used to communicate with the Mobileye system.

The EyeNET adapter enables fast connection between the Mobileye 8 and Mobileye software running on a computer for system calibration and configuration.

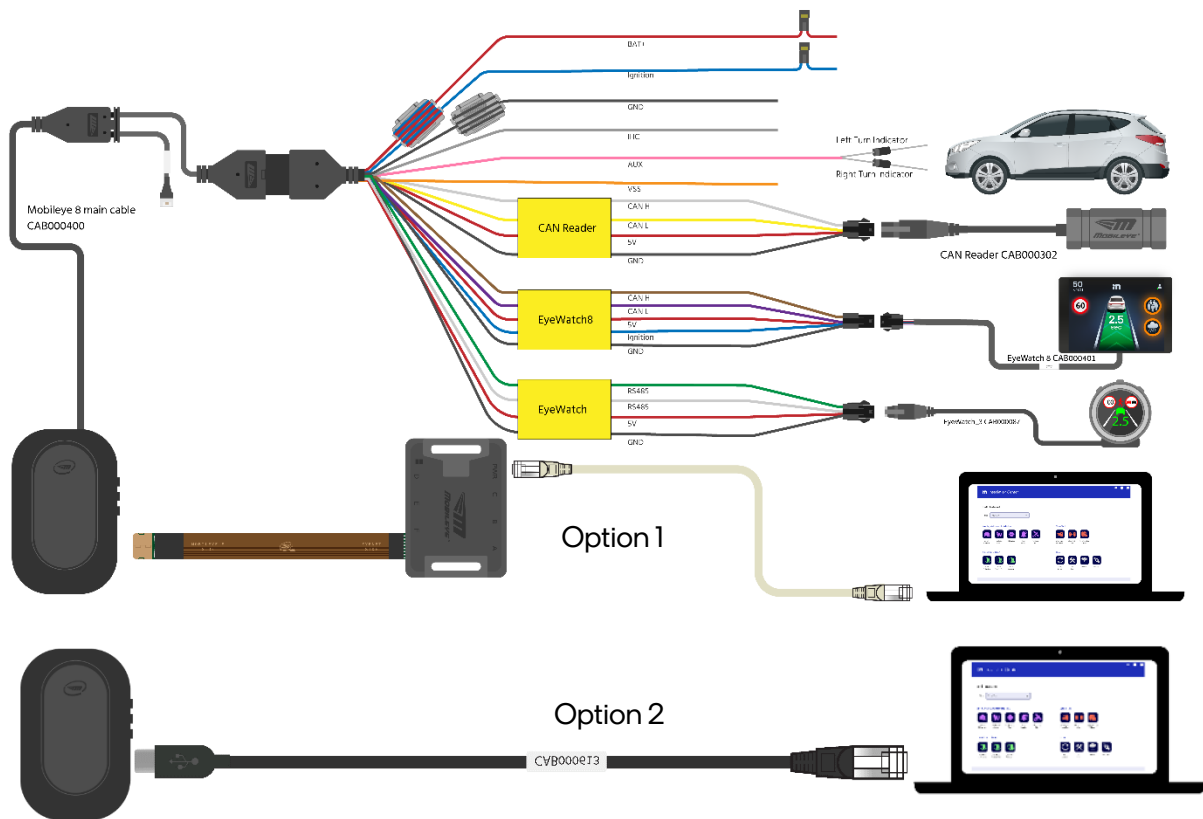

Note

Internet access is mandatory during the configuration and calibration of the Mobileye 8.

7.3 System Calibration

7.3.1 Login

Open the Installation Center application on your computer and login using your personal login details.

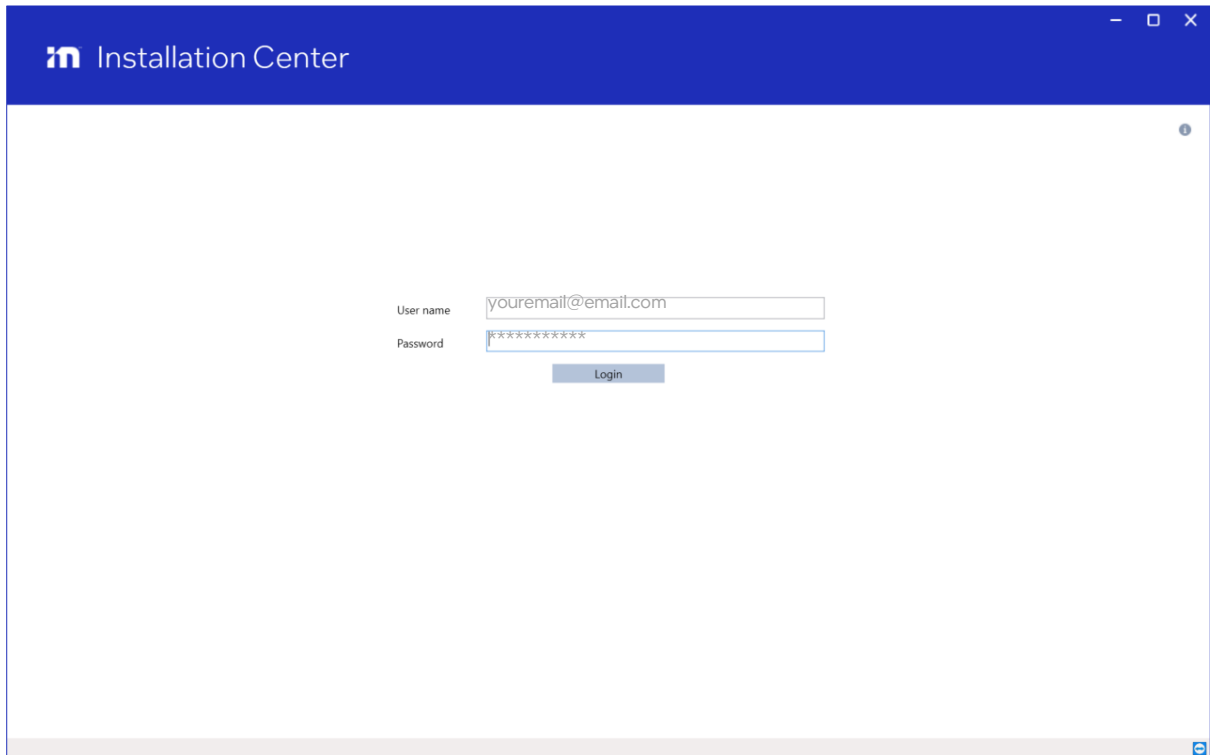

The screenshot shows a window titled "Installation Center" with a blue header bar. The main content area is white and contains a login form. The form has two input fields: "User name" with the text "youremail@email.com" and "Password" with a masked password "*****". Below the fields is a "Login" button. The window has standard OS window controls (minimize, maximize, close) in the top right corner and a small icon in the bottom right corner.

→ Click "Login" to continue.

7.3.2 Login

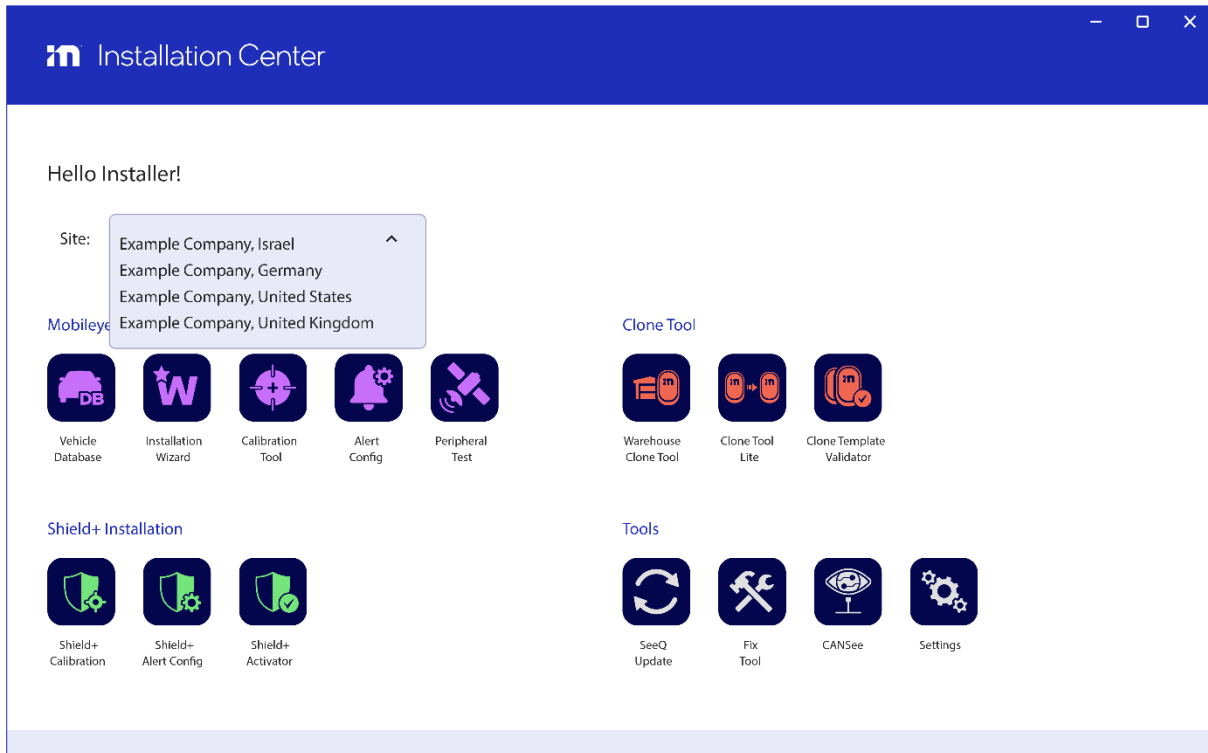

Choose your installation site from the dropdown list.

Click the vehicle database icon  to open the Mobileye vehicle database and browse to find the correct profile of the vehicle you are installing.

In the vehicle database, you can find the following information:

- ❖ Vehicle make/year/model.
- ❖ CAN-bus signals availability
- ❖ CAN-bus wires location + picture

CAN-bus baud rate

Note

- When clicking the "vehicle database" button, no physical connection is required.
- It is possible to continue and open the IC Wizard application directly from the vehicle database.
- If you are already connected to a Mobileye 8 system and have completed the physical connections, you may skip the "vehicle database" and click the "wizard" button to immediately start the installation.

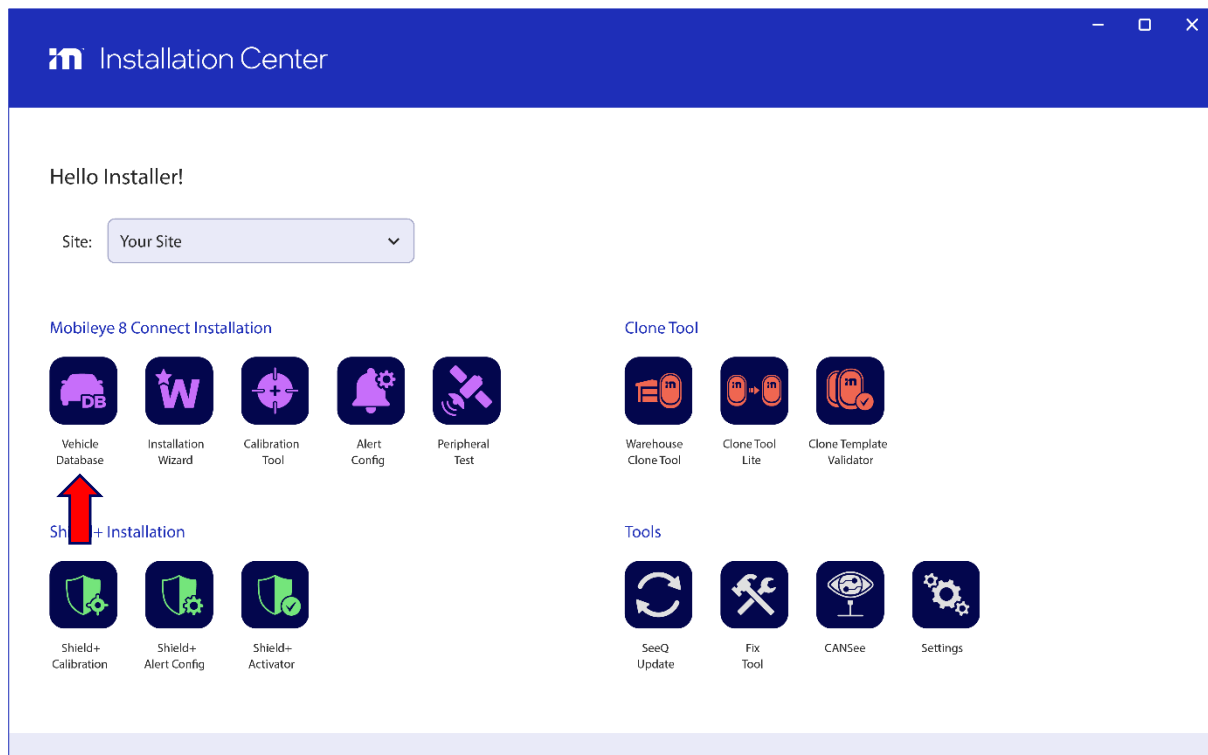

Note

When clicking the "Wizard" button you must be physically connected to a Mobileye 8 system and the system power must be on to continue the calibration process. You will have an option to browse and choose the correct profile of the vehicle you are installing during a standard Wizard run as well.

7.3.3 Vehicle Selection

Choose the correct vehicle profile from the vehicle database.

The Mobileye vehicle database contain CAN information such as: available signals, CAN-bus wires location, bus speed, CAN-bus wires colors or pin number if available and pictures of the vehicle & CAN wires location.

Note

In the event the vehicle into which you are installing is not in the vehicle database, you can either try a similar profile or contact Mobileye support for help with creating a new profile.

VEHICLE DB TOOL

SELECT CAR

Manufacturer: Hyundai
 Car Model: i30
 Year: 2016
 Engine Type: other
 Engine Capacity: 0
 Production Country: N/A
 Trim:
 Profile: Profile 1

DETAILS

Signal	CAN	Analog
Speed	✓	✗
Blinker R	✓	✗
Blinker L	✓	✗
Reverse gear	✗	✗
Wipers	✗	✗
Brake	✓	✗
High beam	✓	✗

Profile

- CAN high
- CAN low
- CAN baudrate 500 kbps
- ODBII high
- ODBII low

Comments

Signals available by CAN:
All signals (except Wipers)

CAN wires can be found in OBD2 connector.

CAN High: Pin 6
CAN Low: Pin 14

Bus Speed: 500,000

Vehicle installed in:
Israel, Oct.2015, (GM)

Start Installing

→ Click "Go to App" to continue.

7.3.4 Connection to SeeQ

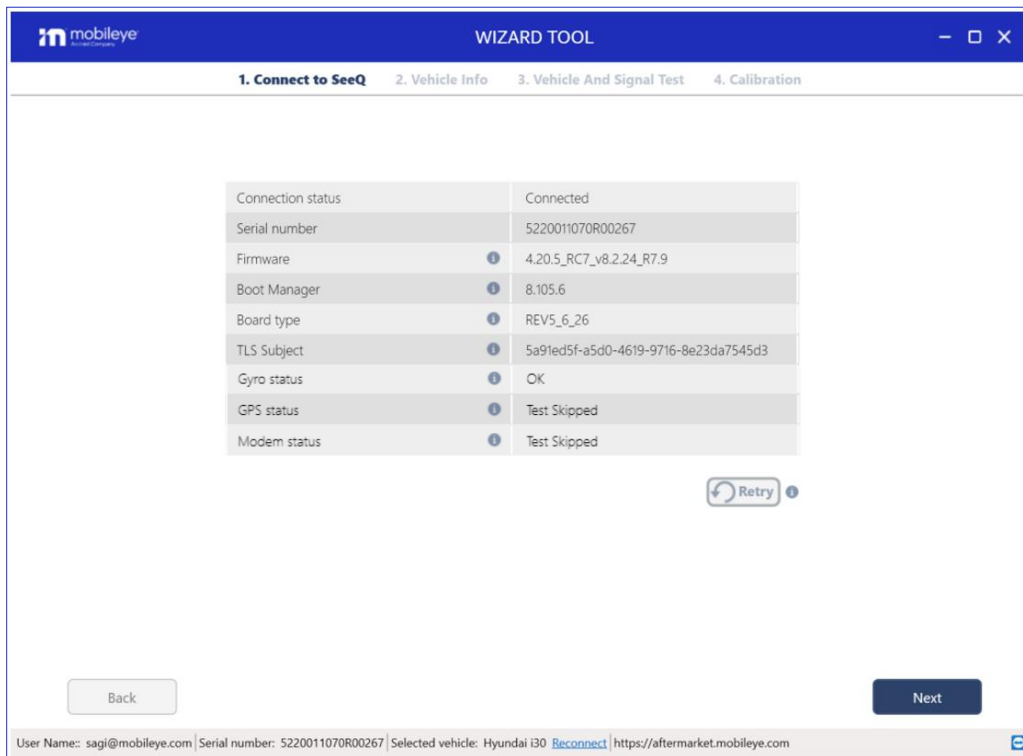

The app will check:

communication status with Mobileye's system and provide system information such as:

- ❖ Connection status
- ❖ System serial number
- ❖ System firmware version

Note

If you click the "retry" button, the app will try to reestablish communication and display the system information if successful.

⇒ Click "Next" to continue.

7.3.5 Vehicle Information

Enter the license number, VIN number and choose the country from the dropdown menu.

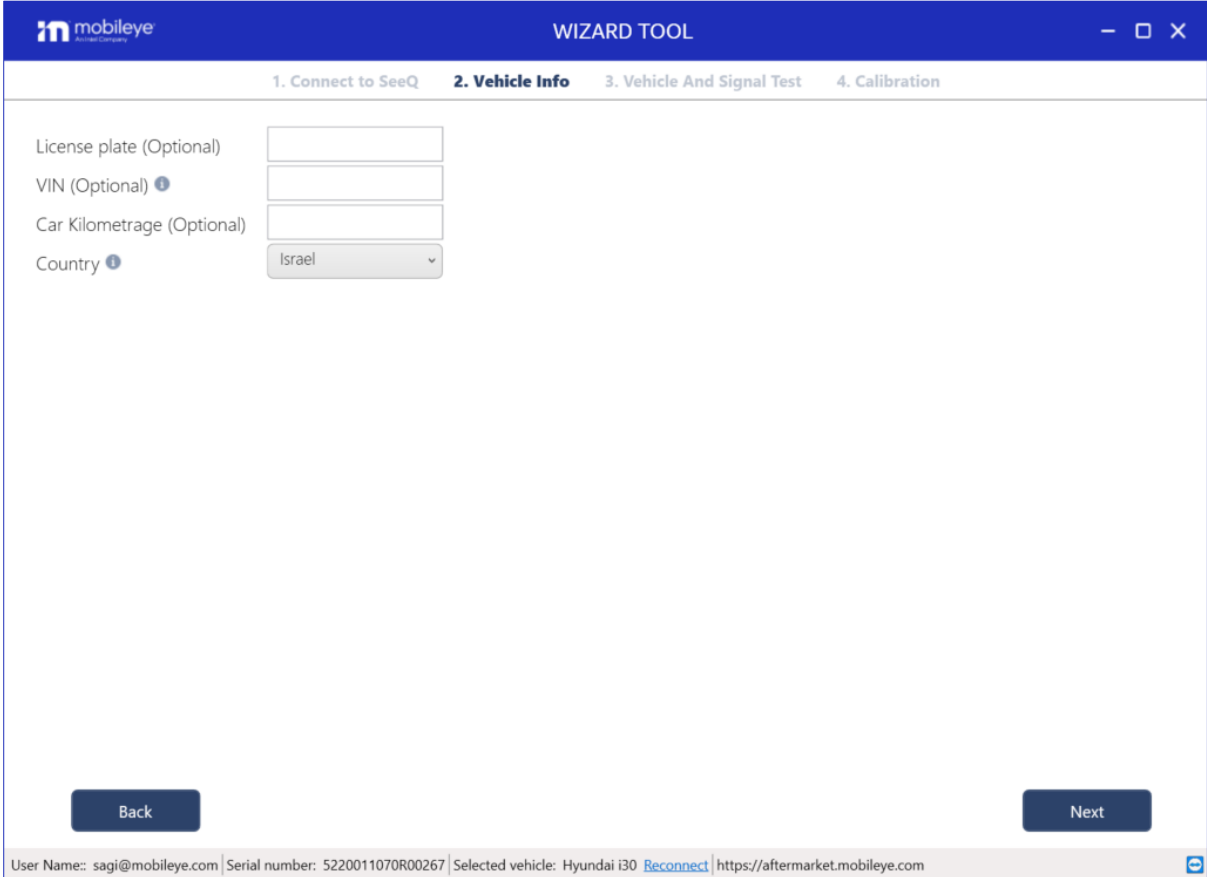

The screenshot shows a software window titled "WIZARD TOOL" with a blue header bar. The window contains a progress bar with four steps: "1. Connect to SeeQ", "2. Vehicle Info", "3. Vehicle And Signal Test", and "4. Calibration". The "2. Vehicle Info" step is currently active. Below the progress bar, there are four input fields: "License plate (Optional)", "VIN (Optional)", "Car Kilometrage (Optional)", and "Country". The "Country" field is a dropdown menu with "Israel" selected. At the bottom of the window, there are two buttons: "Back" on the left and "Next" on the right. A status bar at the very bottom of the window displays the following information: "User Name: sagi@mobileye.com | Serial number: 5220011070R00267 | Selected vehicle: Hyundai i30 [Reconnect](#) | <https://aftermarket.mobileye.com>".

→ Click "Next" to continue.

7.3.6 Vehicle Information

The software will remember and display all the vehicle and profile information you chose earlier. You can always choose a new profile or modify your earlier selection at this time.

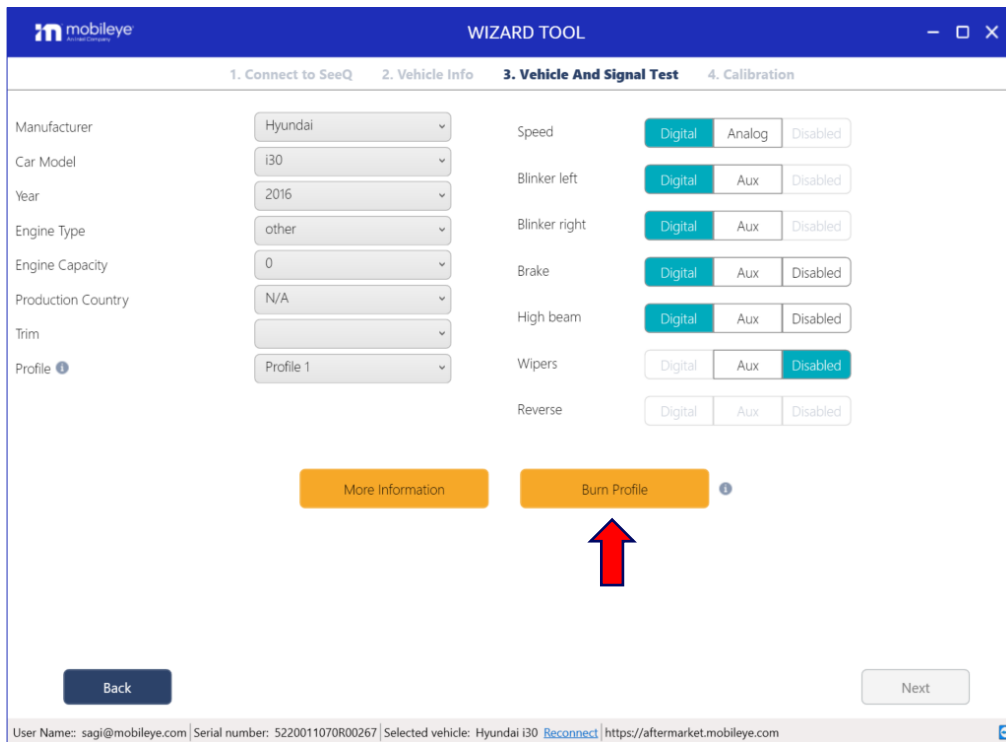

Click → **"Burn selected profile"** to burn and save the profile data into the Mobileye system.

Note

- You can change and burn different profiles until finding the correct profile.
- You cannot proceed with system calibration until you pass the signals test.

7.3.7 Analog Installation

In a case you install the unit in vehicle which speed is not available by CAN, please locate the VSS signal in the vehicle, choose the most similar vehicle profile from the vehicle DB and change the Speed input from "Digital" to "Analog", VSS rate field will be available to be filled according the specific VSS of the relevant vehicle.

If you don't know the vehicle VSS rate, set the value to 5000, Burn the profile as set and check the Vehicle speed vs the Mobileye Installation Center shown speed, if necessary, please adjust the rate so the speed shown will be accurate.

The screenshot shows the 'WIZARD TOOL' interface for the '3. Vehicle And Signal Test' step. The 'Speed' input is set to 'Analog' and the 'VSS' field is highlighted with a red circle. The interface includes dropdown menus for vehicle information and buttons for 'More Information', 'Burn Profile', 'Back', and 'Next'.

Step	Manufacturer	Car Model	Year	Engine Type	Engine Capacity	Production Country	Trim	Profile	Speed	Blinker left	Blinker right	Brake	High beam	Wipers	Reverse
1. Connect to SeeQ															
2. Vehicle Info	Hyundai	i30	2016	other	0	N/A		Profile 1	Digital	Digital	Digital	Digital	Digital	Digital	Digital
3. Vehicle And Signal Test									Analog	Aux	Aux	Aux	Aux	Aux	Aux
4. Calibration															

Buttons: More Information, Burn Profile, Back, Next

User Name: sagi@mobileye.com | Serial number: 5220011070R00267 | Selected vehicle: Hyundai i30 [Reconnect](#) | <https://aftermarket.mobileye.com>





7.3.8 Signal Test

Verify that all signals are detected by the Mobileye system.

Activate each signal and an  icon will be shown when it is detected by the Mobileye system.

Speed signal verification - drive and confirm speed indication in the Mobileye setup wizard approximately matches the speed of the car shown by the speedometer.

 **Note**

- Signals activations are possible only after the speed signal is verified and marked as 
- To proceed to the next step, the full signals test must be successfully completed

→ Click "Next" to continue.

7.3.8.1 Signal Test Troubleshooting

If the signals test failed in all or some of the inputs, please follow the next steps and press "reset test"

- Before any signal test activation, wait until the speed signal green V icon will be shown and only then test the other signals activation.
- Check your connections- make sure the CAN sensor is connected correctly.
- Try to switch CAN High and CAN Low connections- try to flip the CAN Sensor on the CAN wires and reset test again.
- Make sure you connected to the CAN wires as described in the Mobileye Vehicle Database.
- Check the chosen profile- make sure you chose the correct profile, if needed try to choose other similar profile, burn it and check the signals test again.

→ Click "Next" to continue.

7.3.9 Calibration

7.3.9.1 Step 1 – TAC assembly

Place the TAC target in front of & exactly at the center of the vehicle.

When TAC is assembled and open correctly the bottom part of the checkered board TAC should be 90 cm from ground or 165 cm if the TAC is opened and flipped to high level (depending on the camera height).

Mount the camera on the windshield according to Mobileye's guidelines as follows:

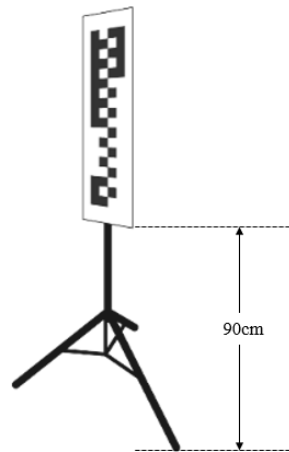

7.3.9.2 Step 2 – Camera attachment

Use the surface cleaner supplied in the kit to clean the attachment area of the windshield and then use a dry paper towel to dry the area and remove residue before attaching the camera.

Mount the camera using the live image feed from the camera unit, showing the grid lines over the TAC target. This image feed will assist you in mounting the camera correctly and within the allowed camera tilt/roll of up to 2°. Use the grid to properly attach the camera with as little tilt/roll as possible.

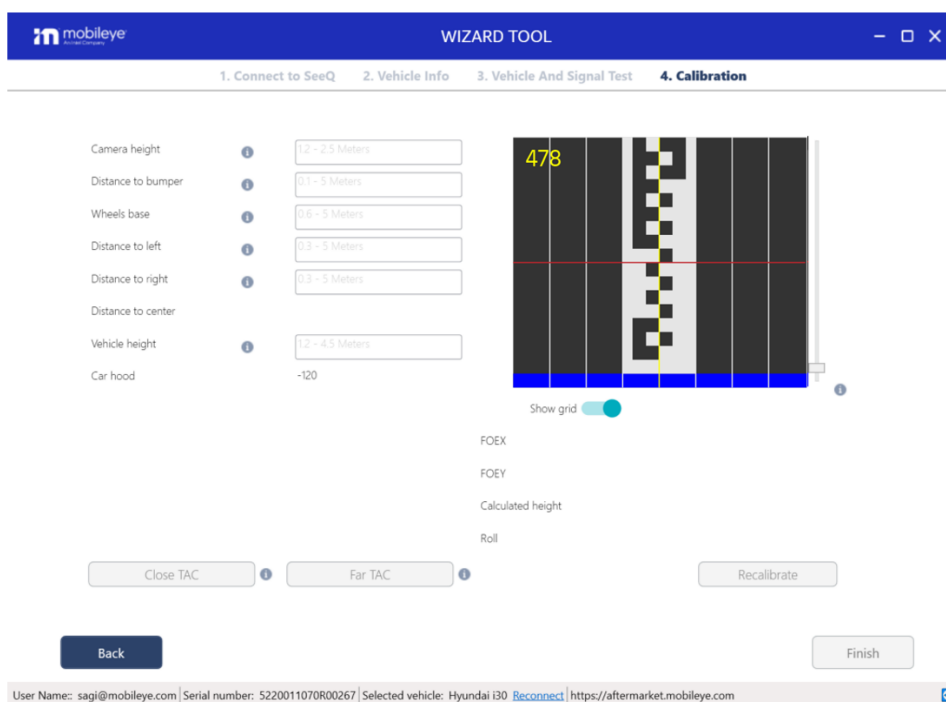

Attach the main camera unit; lining up the IC Wizard **Yellow** line exactly with the camera location on the TAC.

For example:

If the camera is mounted exactly in the center of the windshield, the yellow line should be in the center of the TAC target.

If the camera is mounted off-center, make sure this offset is reflected in the yellow line location on the TAC target.

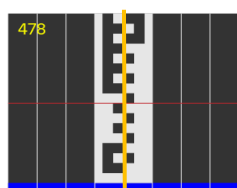

Center

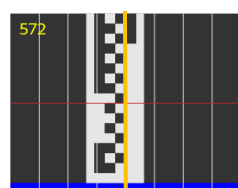

5cm to the right

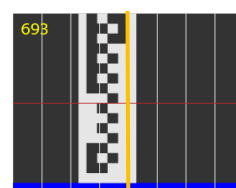

10cm to the right

Deviation Offset

Optimal- center of the windshield, if center not possible, according to the vehicle width:

- a. If the vehicle width measurement is **up to** 1.67 meters- camera can be attached up to 10cm from the windshield center **MAX**.
- b. If the vehicle width measurement is **more** than 1.67 meters- camera can be attached up to 8% of the vehicle width measurement.

Vehicle width in cm X 0.08 = MAX OFFSET

7.3.9.3 Step 3 – Measurements

Caution

Entering any measurement that is not in the acceptable range or not in the correct format will be highlighted in red and will not let you continue to the next step.

Enter each vehicle measurement in the correct field:

WIZARD TOOL

1. Connect to SeeQ 2. Vehicle Info 3. Vehicle And Signal Test 4. Calibration

Camera height

Distance to bumper

Wheels base

Distance to left

Distance to right

Distance to center

Vehicle height

Car hood -120

Show grid

FOEX

FOEY

Calculated height

Roll

Close TAC Far TAC Recalibrate

Back Finish

User Name: sagi@mobileye.com | Serial number: 5220011070R00267 | Selected vehicle: Hyundai i30 | Reconnect | https://aftermarket.mobileye.com

❖ Camera height

Measure the camera height from the camera lens to the ground.



❖ **Distance to bumper** (the distance from the camera to the front bumper).

Measure the horizontal distance from the camera lens to the vehicle's front bumper edge.



Camera height	<input type="text" value="1.2 - 2.5 Meters"/>
Distance to bumper	<input type="text" value="0.1 - 5 Meters"/>
Wheels base	<input type="text" value="0.6 - 5 Meters"/>
Distance to left	<input type="text" value="0.3 - 5 Meters"/>
Distance to right	<input type="text" value="0.3 - 5 Meters"/>
Distance to center	<input type="text" value=""/>
Vehicle height	<input type="text" value="1.2 - 4.5 Meters"/>
Car hood	-120

❖ **Wheels Base** (width of the vehicle wheels)

Measure the distance between the outer edges of the front wheels.

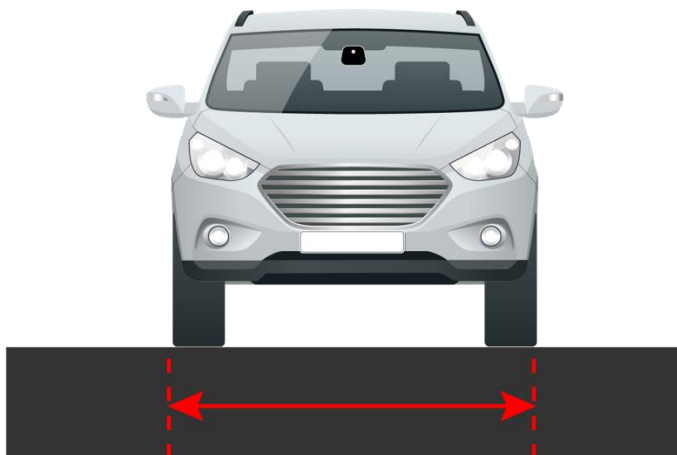

Camera height	<input type="text" value="1.2 - 2.5 Meters"/>
Distance to bumper	<input type="text" value="0.1 - 5 Meters"/>
Wheels base	<input type="text" value="0.6 - 5 Meters"/>
Distance to left	<input type="text" value="0.3 - 5 Meters"/>
Distance to right	<input type="text" value="0.3 - 5 Meters"/>
Distance to center	<input type="text" value=""/>
Vehicle height	<input type="text" value="1.2 - 4.5 Meters"/>
Car hood	-120

- ❖ **Distance to left, distance to right** (the camera distance from the left and right windshield edge).

Measure the lateral distance from the camera lens to both left & right windshield edges.

PLEASE NOTE: Left & Right should be measure from the outside of the vehicle but should be insert to the software as driver perspective sides (see Left &Right on the illustration bellow).

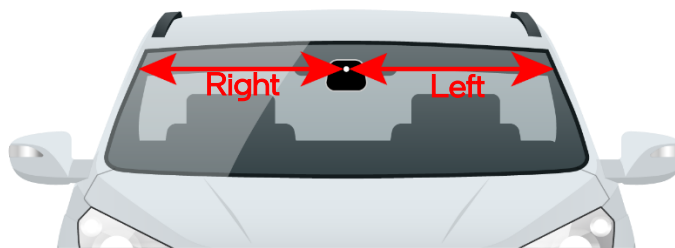

Camera height	<input type="text" value="1.2 - 2.5 Meters"/>
Distance to bumper	<input type="text" value="0.1 - 5 Meters"/>
Wheels base	<input type="text" value="0.6 - 5 Meters"/>
Distance to left	<input type="text" value="0.3 - 5 Meters"/>
Distance to right	<input type="text" value="0.3 - 5 Meters"/>
Distance to center	<input type="text"/>
Vehicle height	<input type="text" value="1.2 - 4.5 Meters"/>
Car hood	-120

- ❖ **Vehicle Height**

Measure the distance from ground to the top of the vehicle.



Camera height	<input type="text" value="1.2 - 2.5 Meters"/>
Distance to bumper	<input type="text" value="0.1 - 5 Meters"/>
Wheels base	<input type="text" value="0.6 - 5 Meters"/>
Distance to left	<input type="text" value="0.3 - 5 Meters"/>
Distance to right	<input type="text" value="0.3 - 5 Meters"/>
Distance to center	<input type="text"/>
Vehicle height	<input type="text" value="1.2 - 4.5 Meters"/>
Car hood	-120

7.3.9.4 Step 4 – Camera angle adjustment

After measuring the camera height and entering it into the Wizard, mark the camera height on the TAC board using a black tape and manually adjust the camera's lens so that the RED line will be parallel to the height mark on the TAC.

Once the red line in the image is lined up with the marking you placed on the TAC, tighten the camera angle adjustment screw.

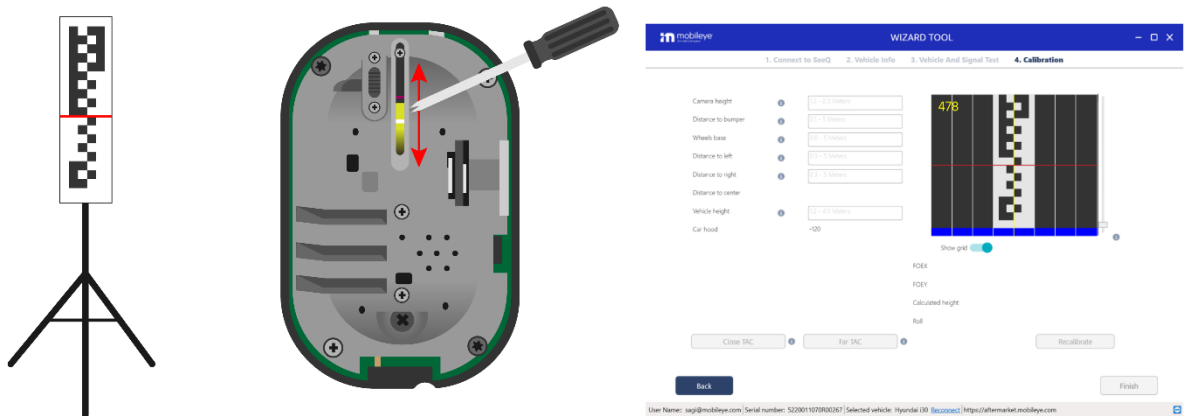

7.3.9.5 Step 5 – Car hood

Drag the scroll bar on the left side of the image to adjust the blue field and prevent the camera from 'seeing' the hood of the vehicle.

See image below:

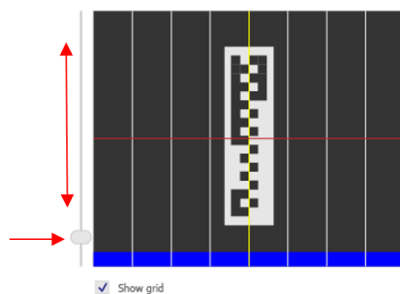

Caution

Perform vehicle hood calibration only if the hood poses a permanent obstruction to the camera's field of view.

If no car engine hood is present in the image, car hood value should remain at the default value of -120

7.3.9.6 Step 6 – Calibration

Once all these measurements have been entered, 2 calibration steps are required:

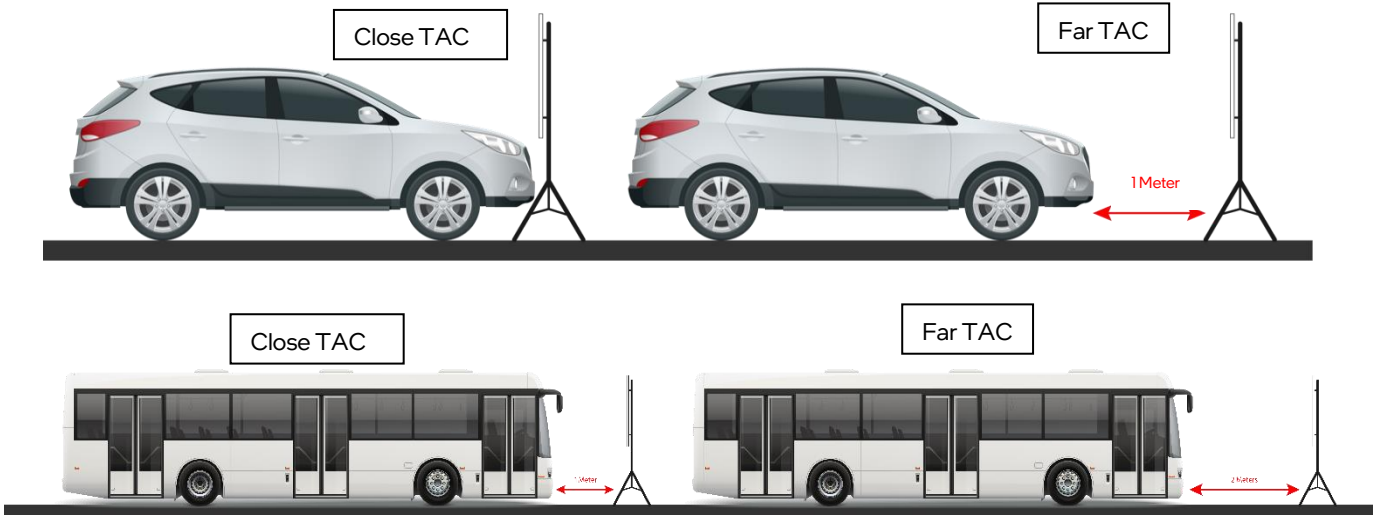

Close TAC

Place the TAC exactly in the center of the vehicle and close to the vehicle bumper.

Press "Close TAC" for close TAC calculation.

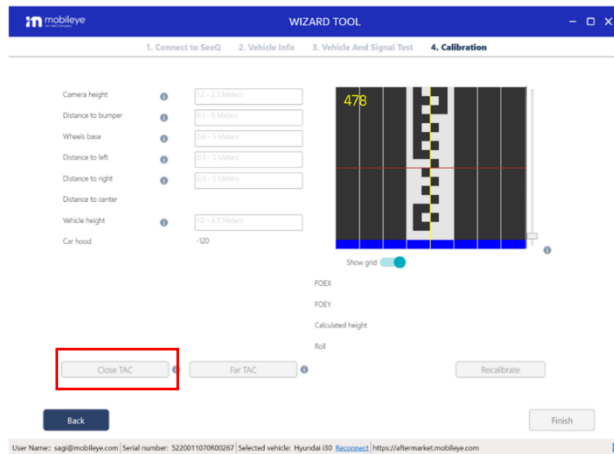

Far TAC

After the close TAC calculation has been successfully completed, a pop-message will appear.

Move the TAC 1-meter away from the current position and Press the “OK” button.

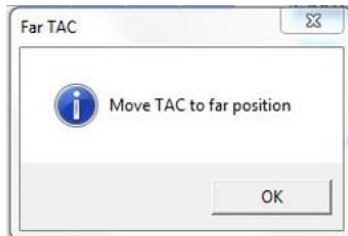

Press the “Far TAC” button to get far TAC calculation.

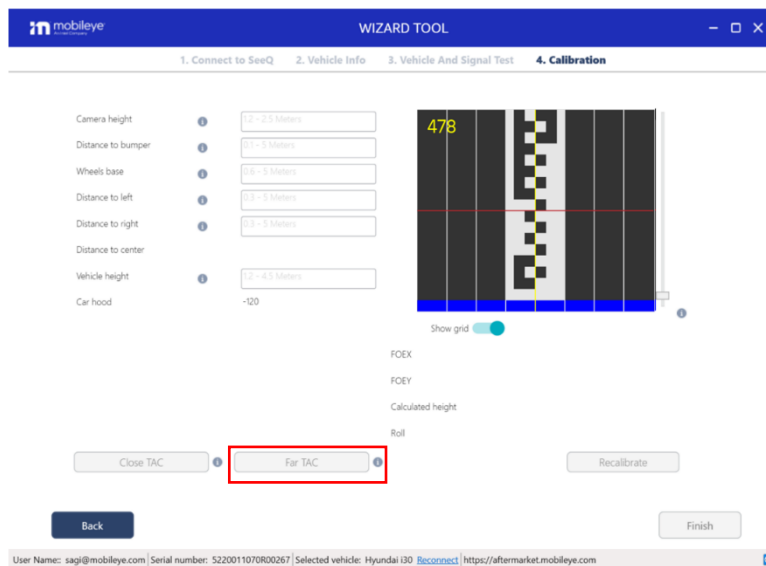

Step 9 – calibration results

The Calibration results should meet the following requirements:

1. FOE X optimal value is 0 (± 15)
2. FOE Y optimal value according to the following table (± 10)

FOE Y OPTIMAL VALUES	
Camera Height (meters)	Expected FOE Y value (± 10)
1.20 – 1.80	0
1.85	27
1.90	28
2.00	30
2.10	32
2.20 – 2.65	40

3. Calculated height- up to 3cm differences
4. Roll – up to 2°

The screenshot shows the 'WIZARD TOOL' interface for calibration. On the left, there is a list of parameters with input fields: Camera height (1.2 - 2.5 Meters), Distance to bumper (0.1 - 5 Meters), Wheels base (0.6 - 5 Meters), Distance to left (0.3 - 5 Meters), Distance to right (0.3 - 5 Meters), Distance to center, Vehicle height (1.2 - 4.5 Meters), Car hood (-120), GPS to Bumper (0.1 - 5 Meters), GPS to Left (0 - 5 Meters), GPS to Right (0.3 - 5 Meters), and GPS Height (0.1 - 4.5 Meters). On the right, there is a camera view showing a checkered target with a yellow '478' value. Below the camera view, there are labels for FOEX, FOEY, Calculated height, and Roll. A red box highlights the following values: FOEX: 0, FOEY: 0, Calculated height: 1.40, and Roll: -0.0050. A red arrow points from this box to the 'Calculated height' field in the main interface. At the bottom, there are buttons for 'Close TAC', 'Far TAC', 'Recalibrate', 'Back', and 'Finish'. The footer shows user and vehicle information: User Name: sagi@mobileye.com, Serial number: 5220011070R00267, Selected vehicle: Hyundai i30, and a 'Reconnect' button.

If calibration results meet the minimum requirements mentioned above, calibration is completed, click "Finish".

8. Appendix A – CAN Reader

9.1 General

The Mobileye 8 CAN-Reader is a new, non-intrusive solution for CAN-bus connection.

No more wrong connections, warranty violations or liability issues. The Mobileye CAN-Reader will allow you to better handle a CAN-bus reading by simply placing the Mobileye CAN-sensor on the vehicle CAN-bus wires without any wire cutting or pinching.

Benefits:

- Non-intrusive installation
- Simply install over the CAN-bus wires, no need to cut, strip, crimp or connect physically
- Read data thru the wire's isolation.
- Fits most vehicles.
- Supports all CAN-bus speeds.
- Reliable CAN-bus data reading
- Fast and simple installation.

9.2 CAN Reader installation (CAB000302)

1. Identify the vehicle CAN-bus wires.



2. Untwist the CAN-bus wires over about 5cm.



3. Place the CAN Reader over the CAN-bus wires as labeled on the CAN Sensor module.



Note: In some cases (if Er-20 shows on the EyeWatch display), you will need to switch between CAN High and CAN Low wires

9.3 Technical Specifications

Mobileye® 8 | Technical Specification Sheet

Mobileye® 8 Main Unit	
PHYSICAL CHARACTERISTICS	
Length	120mm
Width (without lens)	78mm
Height	44mm
Weight	200g
Color	Black
Case material	Plastic & Aluminum
Cable length (cab000400)	3m
Cable diameter	5.8mm (±0.2)
ELECTRICAL CHARACTERISTICS	
Input voltage	10-36VDC
Input current max	12v > 700mA, 24v > 350mA
Max power	8.5w
AMBIENT TEMPERATURE (AS TESTED IN LAB WITH NO RADIATION EFFECT)	
Operation	-20°C to +60°C
Storage temperature	-30°C to +85°C
VISION SENSOR	
Vision sensor	OV10642 RCCC CMOS 1.3MP
Active array size	1280H * 1080V
Optical format	1/2.56"
Size	4.2µm x 4.2µm
Dynamic range	48° (horizontal)
Shutter type	Rolling shutter
Responsivity	4.8V/lux sec (550nm)
Angle of view	52° (horizontal) 42° (vertical)
Focus range	5m to infinity
Image transfer rate	36 fps
AUDIO SYNTHESIZER	
Spl minimum	86dB @ 10cm
EYEQ4® VISION PROCESSOR MAIN FEATURES	
Hyper-thread 64bit RISC interAptiv MIPS CPU	
1GB Ethernet Port (Service port for EyeNET)	
128MB Flash x2 (for code memory redundant)	
2 x 1.6GHz, 32bit LPDDR4 SDRAM interfaces	
4 x MIPI CSI-2 Rx serial video and image preprocessing	
1 x parallel video image preprocessing input port	
3 x CAN ports (>1Mbps)	
3 x UART ports (5Mbps)	
3 x I2C Interfaces	
MANUFACTURE STANDARD	
Mobileye 8 manufactured in ISO/TS 16949 certified	

Caution

Beware when removing the system after operation as it may be hot.

For your safety, please use gloves.

Mobileye® 8 | Display unit Specification Sheet

EyeWatch Display Units		
PHYSICAL CHARACTERISTICS	EYEWATCH 3	EYEWATCH 8
Diameter	49mm	Width 84.5mm 25mm
Depth	66mm (leg open)	Leg closed: 34mm Leg open: 73mm
Height	49mm	57mm
Weight	46g	109g without cable 146g with cable
Color	Black	Black
Case material	Plastic	Plastic & Aluminum
Cable length	3m	2.5m
Cable diameter	3mm (±0.2)	3mm (±0.2)
ELECTRICAL CHARACTERISTICS		
Input voltage	5VDC	10-36VDC
Input current	50mA	120mA @ 12V
AMBIENT TEMPERATURE (AS TESTED IN LAB WITH NO RADIATION EFFECT)		
Operation temperature	-20°C to +60°C	-20°C to +60°C
Storage temperature	-30°C to +85°C	-30°C to +85°C
Operating humidity	Up to 95%	Up to 95%
DISPLAY CHARACTERISTICS		
Screen size	1.5"	3.2"
Contrast ratio	250	500
Surface luminance	LCD full color – 40mcd (min)	900 cd/m ²
Viewing angle	100°	45°/45°/45°/20°
Resolution	128 x 128 pixels	240 x 320 RGB
ADDITIONAL FEATURES		
Display colors		262k
Light sensor for automatic view day/night	Yes	Yes

Mobileye® 8 | Certificates

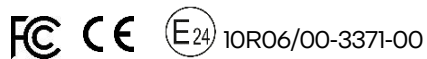

10R06/00-3371-00

Mobileye®, an Intel company
www.mobileye.com

© 2019 Mobileye Vision Technologies Ltd. All rights reserved.
 Reproduction in whole or in part without written permission is prohibited.

9. Appendix B – up/down configuration

9.1 General

Mobileye 8 is based on a smart camera, which is installed on the vehicle's front windshield. To suit all vehicle models (cars, trucks, buses) the smart camera main cable has two configurations: up and down.

All Mobileye 8 systems are supplied with a default up configuration. A distributor/installer can change the up/down configuration at their discretion.

Changing the Mobileye 8 up/down configuration is a simple but delicate procedure.

Instructions on how to change up/down configurations are listed below:

Required Tools:

- ✓ Philips Screwdriver (Tip Size = PH1)
- ✓ Flat Screwdriver (Tip Size = PH1)

1. Using a flat screwdriver, slide and push out the ellipse cover.



- Using a Philips screwdriver, unscrew the 3 screws and remove the main back cover.

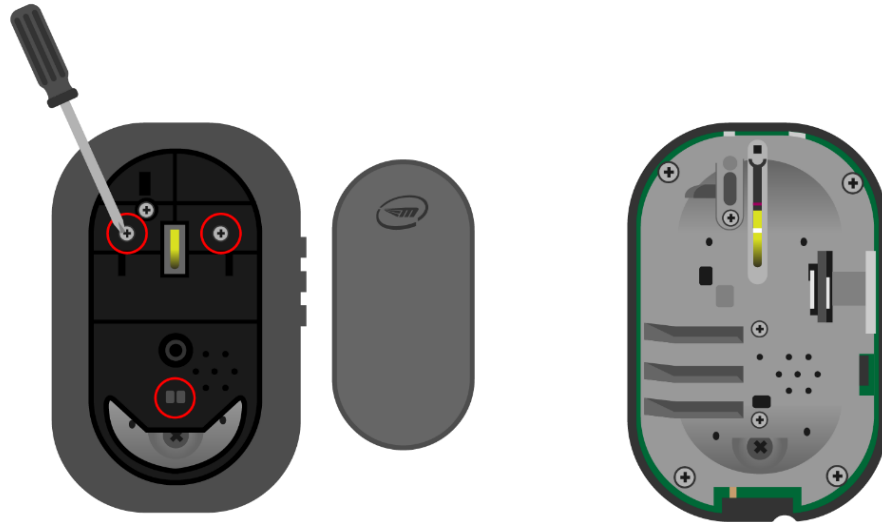

- Using a Philips screwdriver, unscrew to remove the main chassis from the frame.

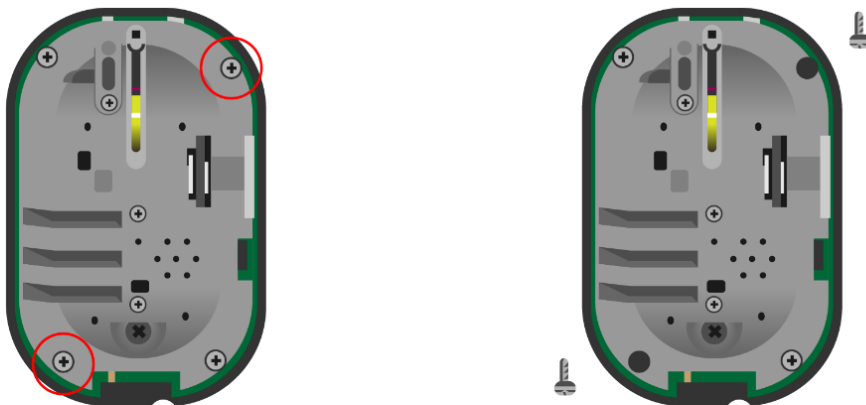

4. Gently remove the chassis from the frame

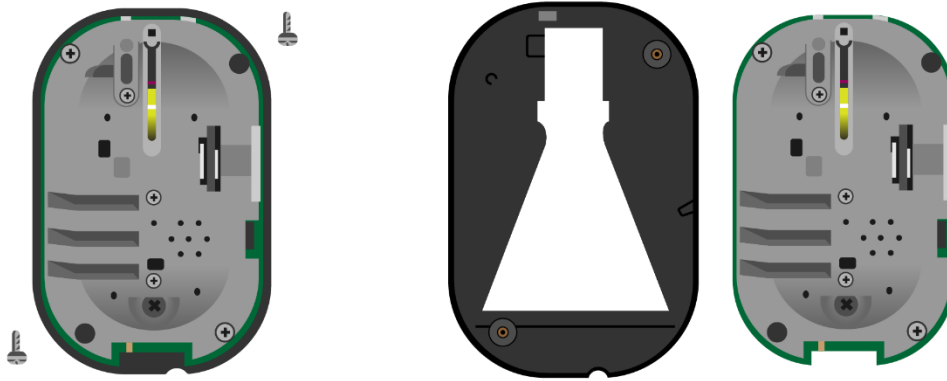

Warning

Do not unscrew the upper left and lower right screws. This will void the warranty!

5. Remove the main cable connector and connect it to the desired configuration.

[Camera up position](#)

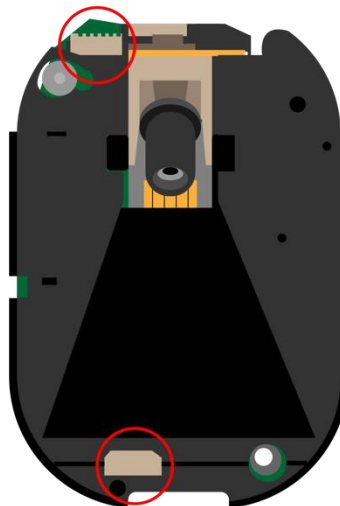

[Camera down position](#)

6. Once completed, reassemble all system components tightening the screws.

10. Appendix C – EyeNET Holder (ASY000451)

10.1 Introduction

The EyeNET holder uses to hold the EyeNET and maintain a stable communication with the Mobileye system.

10.2 Component Overview

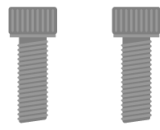

SCR000120

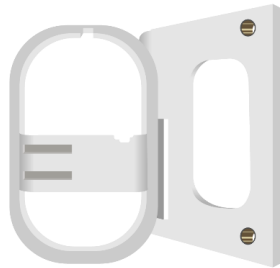

MEC000950

10.3 Assembly

Attach the EyeNET holder on top of the system's metal body.

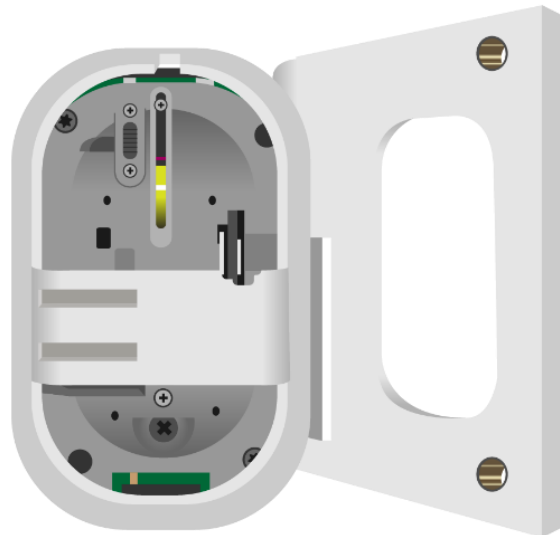

Use to 2x screws to hold the EyeNET

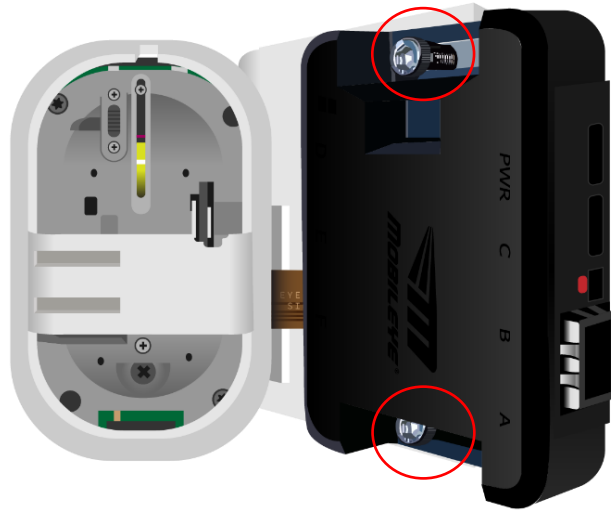

Route the EyeNET flat cable trough the designated gap and connect it in both ends to the Mobileye system and the EyeNET and continue with the calibration process

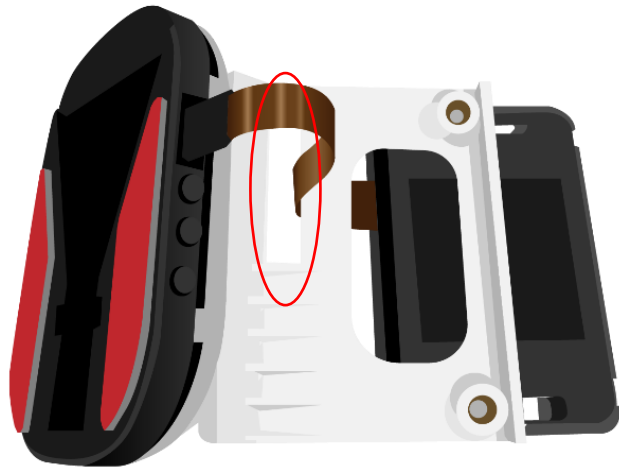

11. Appendix D – Calibration Tool

11.1 Introduction

The Calibration Tool allows to recalibrate the ME8 units without deactivation vehicle profile change such as windshield replacement.

11.2 Instructions

1. To use the Calibration Tool run the app from the Installation Center main screen.

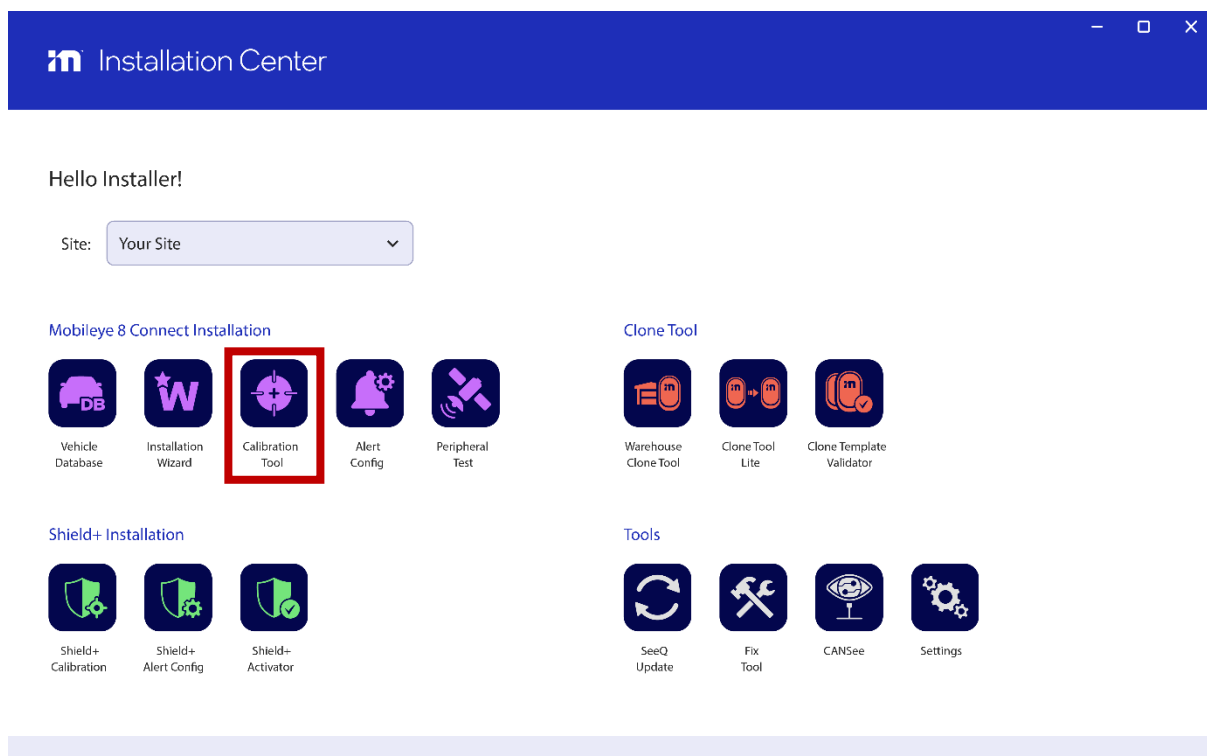

- The tool will check communication with the system and display the system s/n and FW version and display the status of each component.

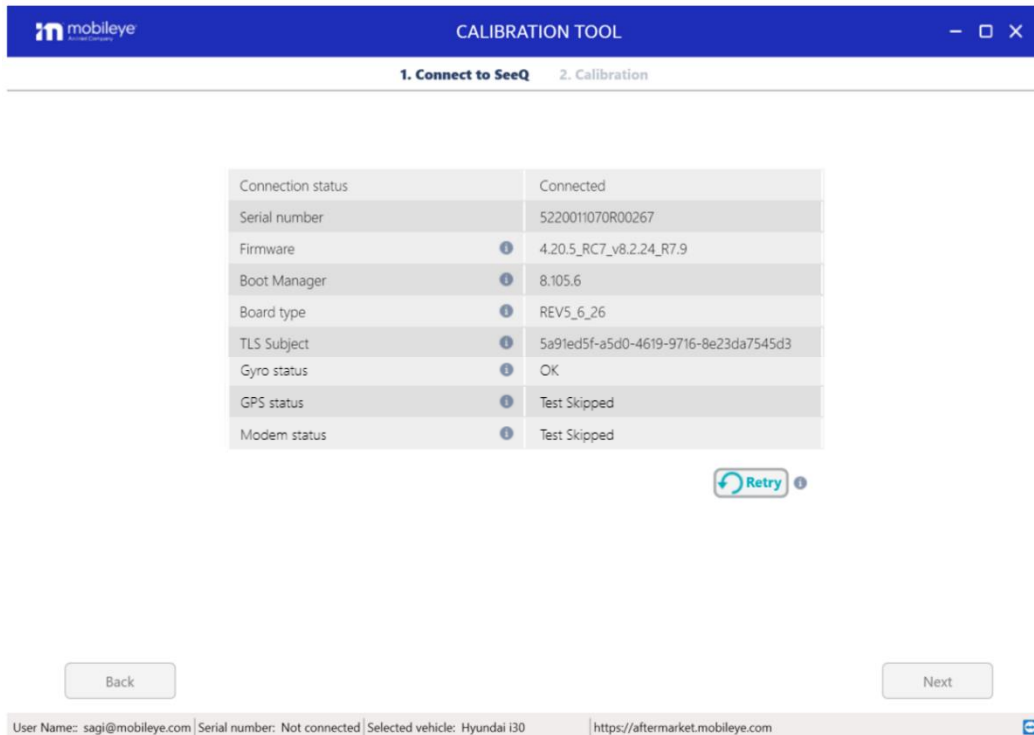

- The camera attachment, measurements and calibration slide will show. To attach, measure and calibrate, please refer to pages 32-42.

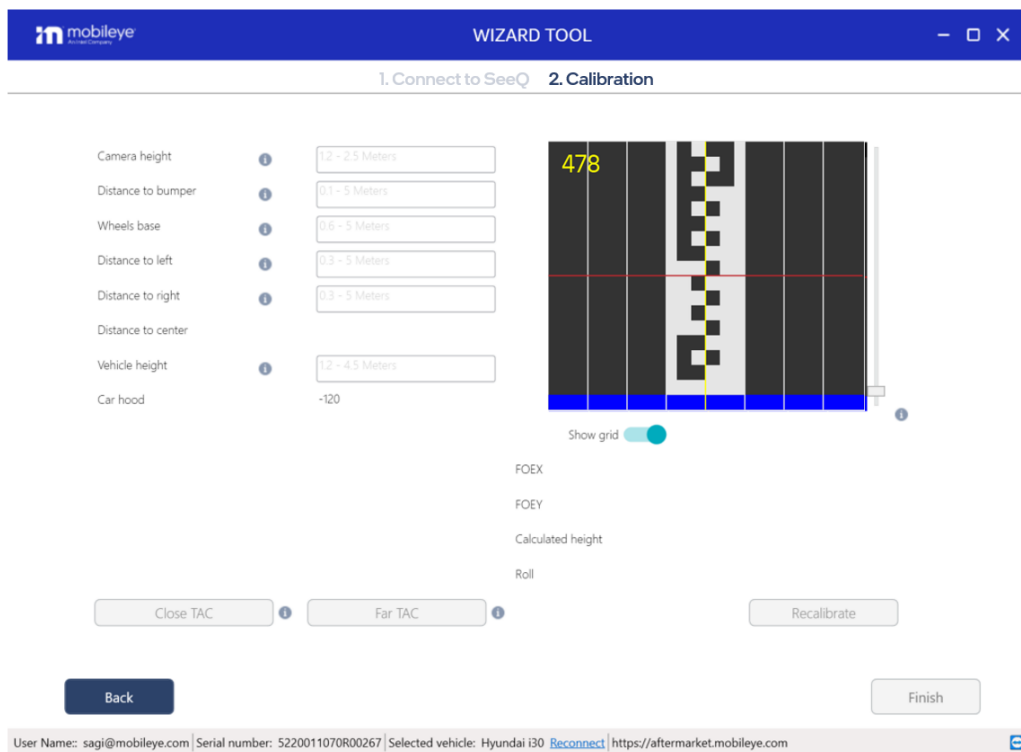

12. Troubleshooting

1. Installer kit:

- Check the TAC assembly.
- Check the EyeNET adapter and make sure the connectors are not damaged.

2. Installation issues:

If signal test fails, check that:

- You connected the correct CAN wires as instructed in the Mobileye Vehicle DB.
- Make sure you selected the correct profile for the vehicle. If necessary, try to use another profile or proceed to CAN sniffing for a new profile creation.

You can also try to switch the CAN sensor position on the vehicle CAN wires (CAN H and CAN L).

3. Calibration and software issues:

Calibration issues can be related to the 4 parameters required.

- If FOE X is more than ± 15 , check the camera location on the windshield and the position of the yellow line.
- If FOE Y value is more than ± 10 , check the measured camera height, the TAC height and lens angle (red line).
- The calculated camera height difference between what you measured and entered to the system may be up to 3cm.
- If the roll value is more than 2° , make sure that the vehicle calibration surface is flat, and the main camera unit attachment is not rolled.
- If you're having issues with the Installation Center installation on your laptop, make sure your laptop meets the minimum requirements.
- Communication issues can be related to your laptop LAN Port settings. Make sure the LAN Port is set and adjust on your OS.
- If your laptop is not equipped with a LAN Port, use an Ethernet to USB adapter (not included).